



### Lathe upgrade kit part numbers:

P/N 6720/6725—Model 4000/4500 lathes

P/N 6730/6735—Model 4400 lathe

P/N 6780/6785—Model 4000/4500 lathe, leadscrew only

P/N 6790/6795—Model 4400 lathe, leadscrew only

# SHERLINE PRODUCTS

INCORPORATED 1974

## INSTALLING CNC STEPPER MOTOR MOUNTS ON A SHERLINE LATHE

### USING THE TEMPLATE BLOCKS TO LOCATE NEW MOUNTING HOLES FOR THE STEPPER MOTOR MOUNTS

This kit contains two template blocks that will help you locate the holes needed to fit stepper motor mounts to your existing Sherline lathe. (Sherline machines now in production have the table and mill base holes predrilled to make this job easier.) The rectangular block is used to locate the holes in the lathe crossslide table. The round template is used for the lathe bed (leadscrew). These blocks are not hardened, because they will only be used once or twice and the wear on them will be minor. To drill the hole pattern for the stepper motor mount for each axis, follow the steps below:

1. To minimize leadscrew deflection when reinstalling, use the crossslide handwheel to move the table so the handwheel is as close to the saddle as possible. Then move the saddle so it is as close to the leadscrew handwheel as possible.

2. On models with standard handwheels, break loose the 5-40 screw in the center before removing the handwheel. The handwheel gives you a way to hold the leadscrew while breaking the center screw loose.

3. Remove each of the two handwheels by loosening its set screw with a 3/32" hex wrench and pulling it off the shaft. (For adjustable "zero" handwheels, rotate the red collar until the hole lines up with the set screw.)

4. Remove the crossslide thrust from the crossslide table. It is held on by a single 5-40 screw.

5. Remove the leadscrew and thrust from beneath the bed. To do so, remove the socket head cap screw that holds the saddle nut to the saddle. Then remove the two screws that hold the leadscrew thrust to the bed and base. The bed screw is a countersunk screw that comes down from the top of the bed. (Move the tailstock toward the headstock if necessary to expose the screw head.) The other is a socket head screw that comes up from below the base into the bottom of the thrust. Remove the leadscrew/thrust/saddle nut assembly.

6. Bolt the rectangular template to the table using the center hole and one of the 5-40 SHCS provided with the kit. Once level with the table, clamp it in place so it can't move.

7. Using a "C" clamp, clamp the round template to the lathe bed with the hole pattern leveled. (See Fig. 2.) Measure the height of each hole from the top surface unless you are pretty good at knowing when something is level by eye. It is not critical to its function that the stepper motor be mounted level, but it looks much more professional when it is.

8. Using the holes in the template as a drill guide, start each hole about 1/16" deep with a #29 or .136" drill.

9. Remove the template block and finish drilling the holes to .25" deep. Back the drill out to clear chips, add cutting oil and finish drilling the hole in two more steps until a depth of .50" is reached. Countersinking the holes will make it easier to start a tap.

10. Tap the holes to 8-32 to at least .4" deep. Use tapping fluid as you cut the threads. Use the tap carefully. Remember that you are working on part that is relatively expensive to replace if you break a tap off in the hole. Take your time.

11. Make sure there are no burrs on the surface of the part after tapping the hole. Deburr if necessary.

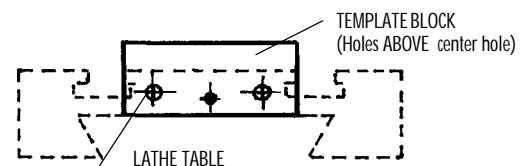

2 HOLES—DRILL .50" DEEP,  
TAP 8-32 x .4" DEEP

FIGURE 1—The rectangular block is used for the lathe table. The two new drilled holes will be drilled ABOVE the existing center hole as shown in the drawing above.

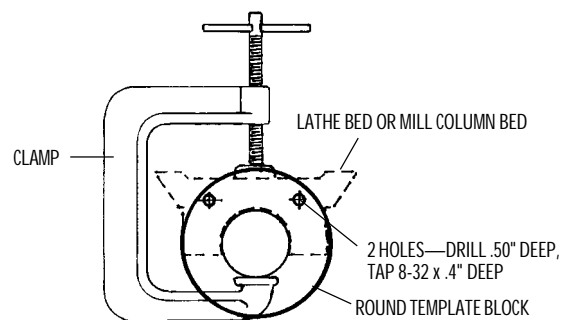

FIGURE 2—The round center of the template block registers in the center portion of the lathe bed. Rotate the template until the holes are level and clamp in place while starting holes.

12. Unscrew the saddle nut from the old leadscrew and thread it onto the new CNC leadscrew. The new collar that replaces the old leadscrew thrust has been temporarily held in place on the leadscrew with tape for shipping. Remove

the tape and attach the collar to the base and bed using the same countersunk screw and socket head screw that held the old leadscrew thrust in place. (In case it came off, the end of the collar with the larger diameter hole goes toward the stepper motor mount.)

13. Attach the stepper motor mount to the bed using the two socket head screws provided. Reattach the saddle nut to the saddle. Adjust the saddle nut. (See adjustment instructions that follow at the end of the next column.)

### INSTALLING THE CROSSLIDE STEPPER MOTOR MOUNT

1. Thread the preload nut onto the crossslide screw.
2. Slide the stepper motor mount over the leadscrew end.
3. Push a coupler through the bearings and over the tapered end of the leadscrew. Attach it to the leadscrew with the new 5-40 screw provided. To tighten, put a hex key through the hole in the side of the mount and into the handwheel shaft set screw. Hold the key to keep the shaft from turning while tightening the 5-40 SHCS in the end of the coupling. (See figure 3.)

**FIGURE 3—**  
Keeping the leadscrew from turning while tightening 5-40 screw and the preload nut

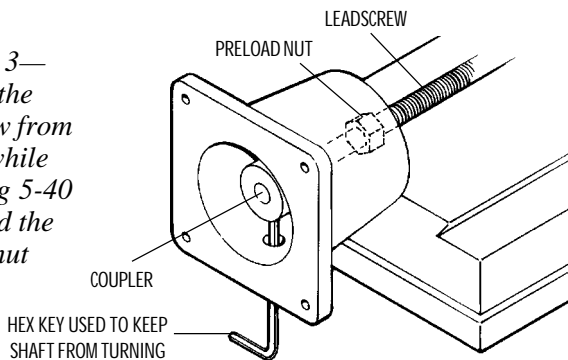

**NOTE:** In the drawing above, the mill base is used as an example, but the same technique is used on the lathe. The hex key adjustment hole may be located on the side of the mount instead of the bottom as is shown here.

4. Using a 3/8" wrench, adjust the preload nut snugly against the end of the bearing. Tighten it enough to remove all endplay. (See Figure 4 to understand how the nut preloads the bearings.) Turn the coupling by hand to make sure it turns freely, then put a little Loctite® on the threads behind the preload nut and let capillary action draw the fluid in. Figure 3 shows using a hex key through the hole in the mount to keep the coupler from turning while tightening the preload nut.

5. Attach the stepper motor mount to the table or bed by installing two 8-32 x 3/4" SHCS provided. This will insure proper alignment. The 8-32 socket head screws go inside the motor mount and thread into the tapped holes in the bed or table. Before tightening the screws, turn the coupler by hand to make sure the mount is properly aligned and is not putting tension on the leadscrew. The holes in the mount are slightly oversize to allow for minor alignment adjustments. Check again for proper alignment by again hand-turning the coupler to assure there is no binding after the final tightening of the screws.

### ATTACHING A STEPPER MOTOR TO THE MOUNT

Sherline stepper motors come with a flat machined on the shaft in the proper location. If you are using another stepper

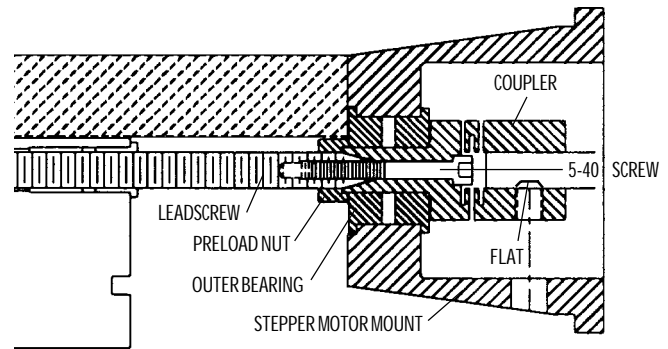

**FIGURE 4—**A cross-section of the stepper motor mount shows how the coupler is attached to the leadscrew.

motor, a flat must be filed or machined on it where the coupling and handwheel set screws are to be tightened against it. See the cross-section on the attached sheet for location of the flat. File a flat or use your mill to machine a flat on the shaft. (If a flat is not provided, the set screw will raise a burr, making it difficult or impossible to remove the shaft from the hole later.) Push the shaft into the coupling and tighten the set screw on the flat. Attach the stepper motor to the mount using the three socket head cap screws provided. The fourth hole can be used for a "cable tie" to secure the cable or for a fourth set screw at your discretion. Attach a handwheel to the shaft on the other end of the stepper motor.

### ADJUSTING THE SADDLE NUT

The adjustment for the saddle nut consists of two flat set screws on either side of a 10-32 socket head cap screw that attaches the saddle nut to the saddle. With the saddle nut located on the leadscrew close to the stepper motor mount, loosen these two screws and slide the saddle into position over the saddle nut. Put the 10-32 socket head cap screw through the saddle and screw it into the saddle nut, but do not tighten it yet.

Adjust the set screws until the flat points touch the saddle nut, and then tighten the 10-32 socket head cap screw. Watch as you tighten to see that the leadscrew doesn't move. If it does, loosen the screw, readjust the set screws and retighten.

What we are attempting to accomplish is to have the saddle nut ride on the leadscrew with the minimum amount of drag. You can check the drag by turning the leadscrew handwheel. If you feel drag, tighten or loosen a single set screw while moving the saddle with the handwheel until the handwheel turns freely, but keep the saddle close to the handwheel. If you adjust the saddle nut while it is in the center of the leadscrew, it may be slightly off center but will feel free until the saddle gets close to either end of its travel. Here, the leadscrew is supported and cannot deflect, so it will bind. If you can't eliminate the binding, tap the saddle nut with a plastic hammer on the leadscrew side while the saddle nut is tightly attached to the saddle and readjust. Don't use the machine with a loose attachment screw as this will cause excessive wear and backlash.

—Joe Martin  
President and owner