

Lathes



D2000 E

Page 22

Centre distance	350 mm
Centre height	110 mm
Power	1.4 kW, 230 V, 50 Hz
Spindle speed indefinitely variable	30 - 2300 r.p.m.
Feed rates	0.085 and 0.16 mm

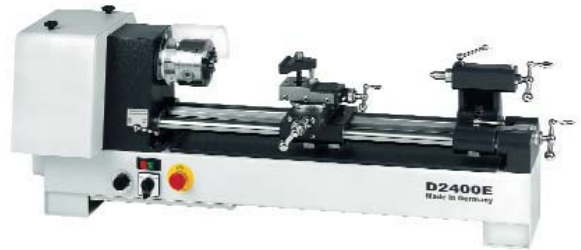

D2400 E

Page 22

Centre distance	500 mm
Centre height	110 mm
Power	1.4 kW, 230 V, 50 Hz
Spindle speed indefinitely variable	30 - 2300 r.p.m.
Feed rates	0.085 and 0.16 mm



D3000 E

Page 22

Centre distance	500 mm
Centre height	110 mm
Power	1.4 kW, 230 V, 50 Hz
Spindle speed indefinitely variable	30 - 2300 r.p.m.
Feed rates infinitely variable	0 - 250 mm/min



D4000 E

Page 32

Centre distance	350 mm
Centre height	100 mm
Power	1.4 kW, 230 V, 50 Hz
Spindle speed indefinitely variable	30 - 2300 r.p.m.
Feed rates	0.085 and 0.16 mm

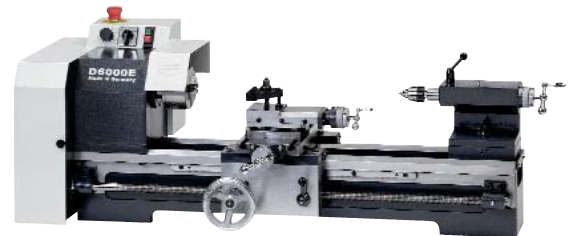

D6000 E

Page 32

Centre distance	600 mm
Centre height	135 mm
Power	1.4 kW, 230 V, 50 Hz
Spindle speed indefinitely variable	30 - 2300 r.p.m.
Feed rates	0.085 and 0.16 mm

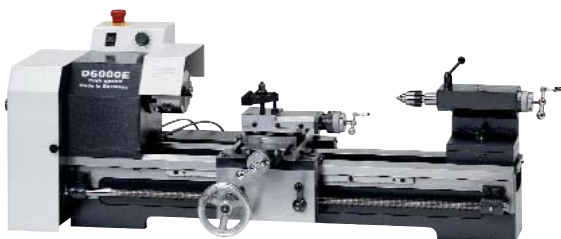

D6000 E high speed

Page 32

Centre distance	600 mm
Centre height	135 mm
Power	2.0 kW, 230 V, 50 Hz
Spindle speed indefinitely variable	100 - 5000 r.p.m.
Feed rates	0.085 and 0.16 mm



DF1680 E

Page 40

Longitudinal X-axis	500 mm
Transverse Y-axis	140 mm
Vertical Z-axis	280 mm
Power	1.4 kW, 230 V, 50 Hz
Spindle speed indefinitely variable	140 - 3000 r.p.m.



CC-D4000 E

Page 48

Centre distance	350 mm
Centre height	100 mm
Power	1.4 kW, 230 V, 50 Hz
Spindle speed indefinitely variable	30 - 2300 r.p.m.
Path feed rate	Up to max. 500 mm/min

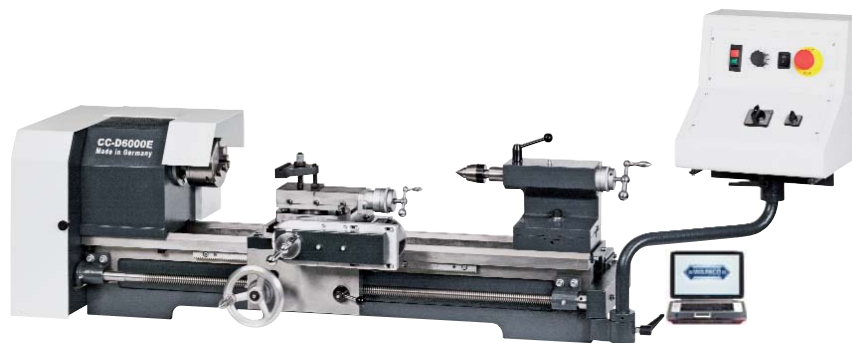

CC-D6000 E

Page 48

Centre distance	600 mm
Centre height	135 mm
Power	1.4 kW, 230 V, 50 Hz
Spindle speed indefinitely variable	30 - 2300 r.p.m.
Path feed rate	Up to max. 1000 mm/min

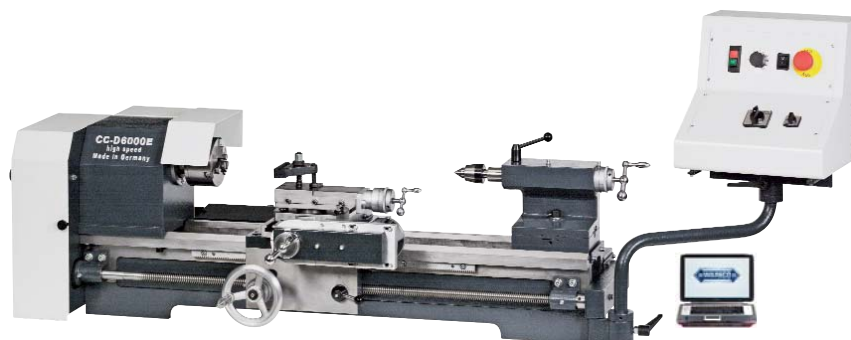

CC-D6000 E high speed

Page 48

Centre distance	600 mm
Centre height	135 mm
Power	2.0 kW, 230 V, 50 Hz
Spindle speed indefinitely variable	100 - 5000 r.p.m.
Path feed rate	Up to max. 1000 mm/min

Milling machines



F1200 E

Page 62

Longitudinal X-axis	260 mm
Vertical Z-axis	280 mm
Transverse Y-axis	150 mm
Work bench	450 x 180 mm
Power	1.4 kW, 230 V, 50 Hz
Spindle speed indefinitely variable	140 - 3000 r.p.m.



F1200 E high speed

Page 62

Longitudinal X-axis	260 mm
Vertical Z-axis	280 mm
Transverse Y-axis	150 mm
Work bench	450 x 180 mm
Power	2.0 kW, 230 V, 50 Hz
Spindle speed indefinitely variable	100 - 7500 r.p.m.



F1210 E

Page 62

Longitudinal X-axis	500 mm
Vertical Z-axis	280 mm
Transverse Y-axis	150 mm
Work bench	700 x 180 mm
Power	1.4 kW, 230 V, 50 Hz
Spindle speed indefinitely variable	140 - 3000 r.p.m.



F1210 E high speed

Page 62

Longitudinal X-axis	500 mm
Vertical Z-axis	280 mm
Transverse Y-axis	150 mm
Work bench	700 x 180 mm
Power	2.0 kW, 230 V, 50 Hz
Spindle speed indefinitely variable	100 - 7500 r.p.m.



F1410 LF

Page 64

Longitudinal X-axis	500 mm
Vertical Z-axis	280 mm
Transverse Y-axis	200 mm
Work bench	700 x 180 mm
Power	1.4 kW, 230 V, 50 Hz
Spindle speed indefinitely variable	140 - 3000 r.p.m.



F1410 LF high speed

Page 64

Longitudinal X-axis	500 mm
Vertical Z-axis	280 mm
Transverse Y-axis	200 mm
Work bench	700 x 180 mm
Power	2.0 kW, 230 V, 50 Hz
Spindle speed indefinitely variable	100 - 7500 r.p.m.

Milling machines



CC-F1200 E

Page 78

Longitudinal X-axis	260 mm
Vertical Z-axis	280 mm
Transverse Y-axis	150 mm
Work bench	450 x 180 mm
Power	1.4 kW, 230 V, 50 Hz
Spindle speed indefinitely variable	140 - 3000 r.p.m.
Path feed rate for	up to max. 1200 mm/min



CC-F1200 E high speed

Page 78

Longitudinal X-axis	260 mm
Vertical Z-axis	280 mm
Transverse Y-axis	150 mm
Work bench	450 x 180 mm
Power	2.0 kW, 230 V, 50 Hz
Spindle speed indefinitely variable	100 - 7500 r.p.m.
Path feed rate for	up to max. 1200 mm/min



CC-F1210 E

Page 78

Longitudinal X-axis	500 mm
Vertical Z-axis	280 mm
Transverse Y-axis	150 mm
Work bench	700 x 180 mm
Power	1.4 kW, 230 V, 50 Hz
Spindle speed indefinitely variable	140 - 3000 r.p.m.
Path feed rate for	up to max. 1200 mm/min



CC-F1210 E high speed

Page 78

Longitudinal X-axis	500 mm
Vertical Z-axis	280 mm
Transverse Y-axis	150 mm
Work bench	700 x 180 mm
Power	2.0 kW, 230 V, 50 Hz
Spindle speed indefinitely variable	100 - 7500 r.p.m.
Path feed rate for	up to max. 1200 mm/min



CC-F1410 LF

Page 82

Longitudinal X-axis	500 mm
Vertical Z-axis	280 mm
Transverse Y-axis	200 mm
Work bench	700 x 180 mm
Power	1.4 kW, 230 V, 50 Hz
Spindle speed indefinitely variable	140 - 3000 r.p.m.
Path feed rate for	up to max. 1200 mm/min



CC-F1410 LF high speed

Page 82

Longitudinal X-axis	500 mm
Vertical Z-axis	280 mm
Transverse Y-axis	200 mm
Work bench	700 x 180 mm
Power	2.0 kW, 230 V, 50 Hz
Spindle speed indefinitely variable	100 - 7500 r.p.m.
Path feed rate for	up to max. 1200 mm/min

Lathes with cylindrical guideways



Parting off

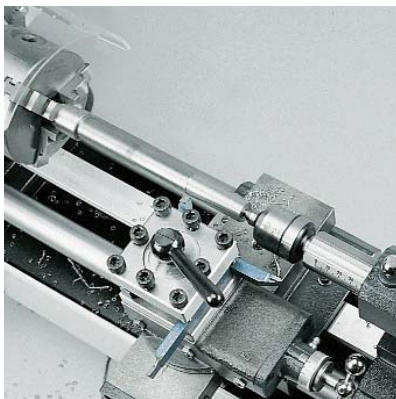

Longitudinal turning



Thread cutting



Taper turning

WABECO technology has proofed itself - the fact that thousands of lathes with massive cylindrical guideways have been sold without a complaint speaks for itself.

You want to turn with precision!

WABECO lathes guarantee you ultimate precision covering the entire working range of the lathe. **Production in Germany** on state-of-the-art machine tools guarantees this. The result is WABECO lathes made to toolmaker's accuracy.

You want quality!

WABECO lathes are produced on state-of-the-art machine tools with a machine precision in accordance with DIN (German Industrial Norm). In order to guarantee our quality, we run tests during assembly and perform a written final test report. This is composed of, among other things, (declaration of average-value specifications): truth of rotation of the work spindle 0.005 mm, cylindrical turning with finishing cut to 100 mm flying 0.01 mm, cylindrical turning with finishing cut to 300 mm between centres 0.015 mm.

You want a robust lathe!

By means of the powerful and infinitely variable drive, it is possible, for example, with round bars of steel with a diameter of 50 mm, to turn down diameters of a work piece by 5 mm with one feed operation. **We would be glad to supply the proof.**

You want a wear-free lathe!

By means of our cylindrical guideways, optimal swarf removal is ensured. Swarf scrapers in the tool slide prevent dirt and swarf entering the guideways. We offer a **10-year warranty** on the guideway pillar.

You want using over generations!

This is guaranteed by in-house design and construction. The supply of replacement parts is also guaranteed for decades.

You want expert advice!

If you have technical inquiries or you wish to be advised in selecting the most suitable lathe and the corresponding accessories for your requirements, our WABECO team is at your disposal for advice.

You want safety!

The lathes' electrical systems have been constructed in accordance with the VDE (Association of German electrical technicians' regulations).

You want a warranty!

We offer you a **5-year warranty** - the warranty does not cover parts subject to wear.

High torque - thanks to the countershaft the lathes have high torque inserted between the drive and the work spindle and this is ideal for machining materials which are hard and difficult to cut.

Extremely silent running by means of modern, electronically regulated drive technology.

Overload clutch - to prevent damage to the feed system, the lead screw and the lead screw drive are connected to the overload clutch.

Rigid work spindle - the rigid work spindle is mounted on 2 precision-DIN adjustable tapered roller bearings. The centering of the work spindle nose is in accordance with DIN 6350.

Universally adjustable cross table - all parts of the cross table are made of high-quality grey cast iron and the dovetail guides are adjustable and play-free. Milled graduations in the graduated collars make cuts in the hundredths range possible. The upper slide can be rotated 360° on the traverse slide in order to turn different tapers.

Powerful tailstock - in order to turn slender tapers, the upper part of the tailstock can be adjusted. The tailstock sleeve is provided with a internal morse taper MT2. A graduated scale on the sleeve allows the depth setting to be read.

Precision guides - precision-ground high-quality solid steel guide ways guarantee a high level of durability, precision and a long life.

The ON-OFF switch is equipped with a **low voltage release**, i.e. the machine will not re-start automatically in the event of a power failure. The drive electronics are equipped with a multiple fault monitoring circuit and this permits a smooth start under all operation conditions.

Easy maintenance - WABECO lathes are easy to maintain because all the modules are easy to reach. The modules can easily be removed for repair purposes.

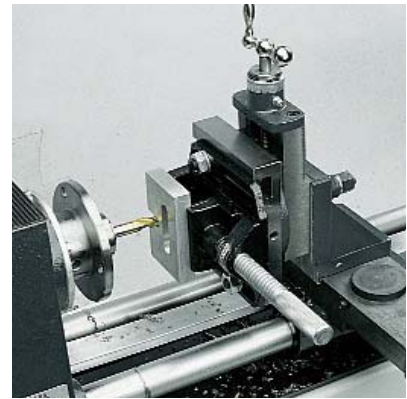

Milling with an angle plate with milling machine table

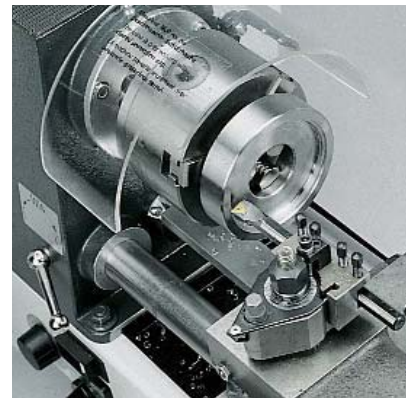

Inside turning

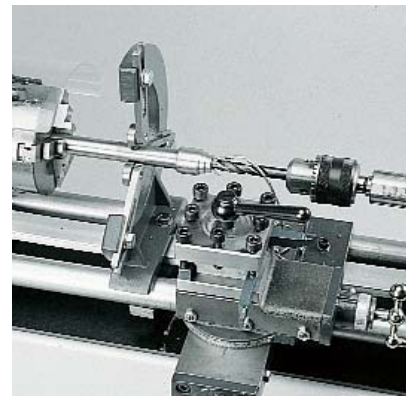

Drilling

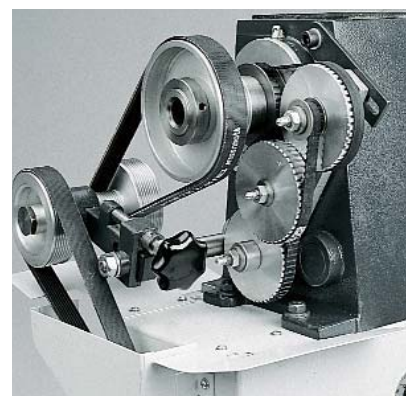

View of gear train

Lathes with cylindrical guideways



D2000 E



D2400 E



D3000 E

... for all lathes

- 5-year warranty
- we guarantee ultimate precision due to **production in Germany** on state-of-the-art machine tools
- made to toolmaker's accuracy with test report
- with electronically infinitely variable drive **30 - 2300 r.p.m.**. Equipped with a strong work spindle drive with dynamic, speed-controlled main drive motor, which can be adjusted by means of a potentiometer over a wide range of cutting speeds
- with single-phase inverse speed motor **1.4 kW, 230 V, 50 Hz** as a direct current model with continuous r.p.m. surveillance
- work spindle bore \varnothing 20 mm (optional \varnothing 30 mm)
- clockwise/anticlockwise rotation of work spindle
- with leading spindle drive and change gear quadrant for **thread cutting**
- **automatic longitudinal feed**
- constant torque throughout the entire speed range
- also available in 110V - 60 Hz and inch models

... especially for lathes D2000 E

- standard lathe chuck with turning and drilling jaw
- fixed lathe centre MT2
- optional - change gears set for metric (0.4-4.0 mm) and inch (10-32 TPI) threads (No. 10179)

with 3-jaw lathe chuck \varnothing 100 mm

Order No. 10108

... especially for lathes D2400 E

- precision lathe chuck with turning and drilling jaw
- fixed lathe centre MT2
- optional - change gears set for metric (0.4-4.0 mm) and inch (10-32 TPI) threads (No. 10179)

with 3-jaw lathe chuck \varnothing 100 mm

Order No. 10200

with 3-jaw lathe chuck \varnothing 125 mm

Order No. 10201

with 4-jaw lathe chuck \varnothing 125 mm

Order No. 10202

... especially for lathes D3000 E

- precision lathe chuck with turning and drilling jaw
- live lathe centre MT2
- automatic longitudinal turning and thread cutting without exchanging loose change gear
- the conventional longitudinal feed of the cross support is accomplished with an angular gear
- the automatic longitudinal feed is infinitely adjustable by means of a potentiometer
- the feed direction can be selected by means of a switch
- change gears set for threading metric (0.4-4.0 mm) and inch (10-32 TPI) threads

with 3-jaw lathe chuck \varnothing 100 mm

Order No. 10300

with 3-jaw lathe chuck \varnothing 125 mm

Order No. 10301

with 4-jaw lathe chuck \varnothing 125 mm

Order No. 10302

Technical data



	D2000 E	D2400 E	D3000E
Centre distance	350 mm	500 mm	500 mm
Centre height	110 mm	110 mm	110 mm
Power 230 V, 50 Hz	1.4 kW	1.4 kW	1.4 kW
Spindle speed infinitely variable	30 - 2300 r.p.m.	30 - 2300 r.p.m.	30 - 2300 r.p.m.
Spindle bore	20 mm - optional 30 mm	20 mm - optional 30 mm	20 mm - optional 30 mm
Taper in spindle nose	MT3 only if spindle bore 20 mm	MT3 only if spindle bore 20 mm	MT3 only if spindle bore 20 mm
Ø-of chuck work above cross slide rest	126 mm	126 mm	126 mm
Travel of cross slide	110 mm	110 mm	110 mm
Travel of longitudinal slide	58 mm	58 mm	58 mm
Swivel range of the upper slide rest	360 °	360 °	360 °
max. height of turning tools	20 mm	20 mm	20 mm
Truth of rotation of spindle nose	0.005 mm	0.005 mm	0.005 mm
Cylindrical turning to 100 mm unsupported	0.01 mm	0.01 mm	0.01 mm
Ø of chuck work, measured above the guiding bars	220 mm	220 mm	220 mm
Travel of tailstock sleeve	65 mm	65 mm	65 mm
Tailstock sleeve taper	MT2	MT2	MT2
Tailstock offset range	± 10 mm	± 10 mm	± 10 mm
Automatic feed	0.085 mm optional 0.16 mm	0.085 mm optional 0.16 mm	0 - 250 mm/min infinitely variable
Thread pitch metric thread inch thread	optional 0.4-4.0 mm 10-32 TPI	optional 0.4-4.0 mm 10-32 TPI	0.4-4.0 mm 10-32 TPI
Machine dimensions (W x H x D)	1050 x 410 x 420 mm	1200 x 410 x 420 mm	1140 x 410 x 420 mm
Weight net without packing	59 kg	65 kg	71 kg

- Technical details are subject to change -

Work spindle bore \varnothing 30 mm

- no retrofitting
- without morse taper

Order No. 10278

Change gears set

- for optional retrofitting
- for metric (0.4-4.0 mm) and inch (10-32TPI) threads
- the change gears are part of the standard equipment for the **D3000 E**



Order No. 10179

Pair of toothed wheels for left-hand thread

- for optional retrofitting

Order No. 10180

Pan for coolant and cutting

- for optional retrofitting



for D2000

Order No. 10174

for D2400 E/D3000 E

Order No. 10175

Base cabinet

- H 85 x W 106 x D 45 cm
- with 2 lockable doors and 2 shelves
- made of powder-coated sheet steel



Order No. 10267

Levelling elements

- vibration pick up and absorption element
- \varnothing 80 mm, thread M10
- prevents the machine and cabinet moving
- for precise height adjustment on uneven ground
- 4 levelling elements are required per cabinet/machine



pack. unit: 1 piece

Order No. 10268

Options



Coolant unit with splash guard

- for optional retrofitting
- for cooling and lubrication
- complete with feed pump 230 V, 50 Hz
- flexible hose with stop valve and nozzle
- content coolant: 19 litres

Application: i.e. when processing high alloy steel and aluminium, improves the surface finish, increases tool endurance, prevents built-up edges, maintains dimensional accuracy of work pieces

Order No. 10264

3-axis digital readout system and linear measuring scales

- switchable from lathes to milling machines
- for a precise, fast and reliable production
- smooth installation by exact positioning
- no parallax or reading errors
- absolute accuracy of repeat machining
- glass measuring scales are protected against shock and dirt
- colour display, 7-digit position indicator and +/- display
- resolution 0.005 mm
- ergonomically designed folio keyboard - dust and splash guard
- reversible metric/inch
- reversion of count (up or down) by means of operation sign change
- coordinates value setting or origin of zero setting
- data is preserved in the fixed set point memory in the case of a power cut
- incremental or absolute measurement input
- parameter input
- diameter or radius readout
- display of the axes Z0 and Z1 with adding function, either the addition value or the individual values are displayed
- can be installed by the customer



**Illustration D3000 E
with 3-axis digital readout system**

3-axis digital readout system		Order No. 10280
Linear measuring scales for transverse X-axis	measuring length 170 mm	Order No. 10284
Linear measuring scales for longitudinal Z-axis		
■ for D2000 E	measuring length 320 mm	Order No. 10286
■ for D2400 E/D3000 E	measuring length 520 mm	Order No. 10287
Bracket for readout system and protective cover for the glass measuring scales		Order No. 10289
Factory-installed readout system and glass measuring scales		Order No. 10288

Options

Angle plate with milling table

- for optional retrofitting
- for drilling and milling
- can be traversed in 3 axis
- work bench 130 x 100 mm
- work bench can be rotated infinitely variable 360°

Order No. 10270

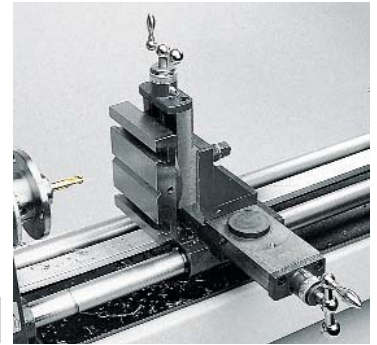

Start set 1

- for lathes **D2000 E/D2400 E**

consisting of:

- universal carbide tipped tools set 6-pieces
- Live lathe centre MT2
- precision quick-action drill chuck
- taper shaft for drill chuck

Order No. 10990



Start set 2

- for lathes **D2000 E/D2400 E/D3000 E**

consisting of:

- universal carbide tipped tools set 6-pieces
- precision quick-action drill chuck
- taper shaft for drill chuck
- quick-change tool holder, basic body
- holder for drill steel
- holder for turning steel

for lathes D2000E/D2400 E additional consisting of:

- Live lathe centre MT2

for D2000 E/D2400 E

Order No. 10991

for D3000 E

Order No. 10992



Lathes with prismatic cast iron bed

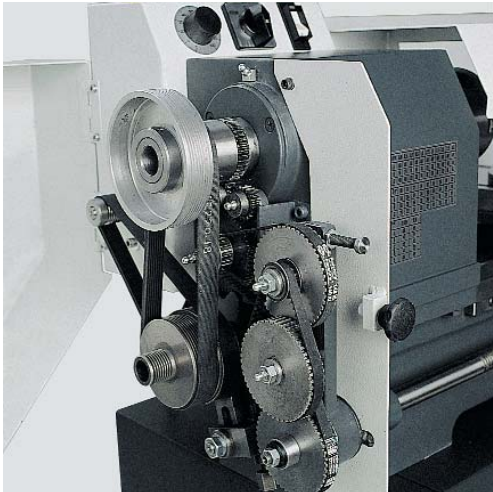

View of gear train



Drilling with stay



Thread cutting

You want to turn with precision!

WABECO lathes guarantee you ultimate precision covering the entire working range of the machine. **Production in Germany** on state-of-the-art machine tools guarantees this. The result is WABECO lathes made to toolmaker's accuracy.

You want quality!

WABECO lathes are produced on state-of-the-art machine tools with a machine precision in accordance with DIN (German Industrial Norm). In order to guarantee our quality, we run tests during assembly and perform a written final test report. This is composed of, among other things, (declaration of average-value specifications): truth of rotation of the work spindle 0.005 mm, cylindrical turning with finishing cut to 100 mm flying 0.01 mm, cylindrical turning with finishing cut to 300 mm between centres 0.015 mm.

You want a robust lathe!

By means of the powerful and infinitely variable drive, it is possible, for example, with round bars of steel with a diameter of 50 mm, to turn down diameters by 10 mm with one feed operation. **We would be pleased to proof it to you.**

You want a wear-free lathe!

Swarf scrapers with felt in the tool slide prevent dirt and swarf entering the guideways.

You want generations of use!

This is guaranteed by in-house design and construction. The supply of replacement parts is also guaranteed for decades.

You want expert advice!

If you have technical inquiries or you wish to be advised in selecting the most suitable machine and the corresponding accessories for your requirements, our WABECO team is at your disposal for advice.

You want safety!

The lathes' electrical systems have been constructed in accordance with the VDE (Association of German electrical technicians' regulations).

You want a warranty!

We offer you a **5-year warranty** - the warranty does not cover parts subject to wear.

Engine bed - the hardened, rigid machine bed is made of multiple diagonally ribbed grey cast iron. The vee guides are ground.

High torque - on the work spindle allows working without problems even in the lower speed ranges for example when machining materials which are hard and difficult to cut.

Extremely silent running by means of modern, electronically regulated drive technology.

Rigid work spindle - the rigid work spindle is mounted on 2 adjustable precision DIN tapered roller bearings. The centering of the work spindle nose is in accordance with DIN 6350.

Tailstock - the housing is made of grey cast iron and centered on the engine bed by means of a hand scraped vee groove.

Tumble gear - can be switched on alternatively for left or right hand thread.

Universal adjustable cross table - all parts of the cross table are made of high-quality grey cast iron and the dovetail guides are adjustable and play-free. Milled graduations in the graduated collars make cuts in the hundredths range possible. The upper slide can be rotated 360° on the transverse slide in order to turn different tapers.

Powerful tailstock - in order to turn slender tapers, the upper part of the tailstock can be adjusted. The tailstock sleeve is provided with an internal morse taper MT2. A graduated scale on the sleeve allows the depth setting to be read.

The ON-OFF switch is equipped with a **low voltage release**, i.e. the machine will not re-start automatically in the event of a power failure. The drive electronics are equipped with a multiple fault monitoring circuit and this permits a smooth start under all operation conditions.

Easy maintenance - WABECO lathes are easy to maintain, because all the modules are easy to reach. The modules can easily be removed for repair purposes.



Inside turning



Knurling



Turning with collet chuck

Lathes with prismatic cast iron bed



D4000 E
with base cabinet and
coolant unit



D6000 E
with base cabinet



D6000 E
with base cabinet and
coolant unit



D6000 E
with ball screws incl. lead-or ball screw protective
cover, base cabinet and coolant unit

Lathes with prismatic cast iron bed



D4000 E

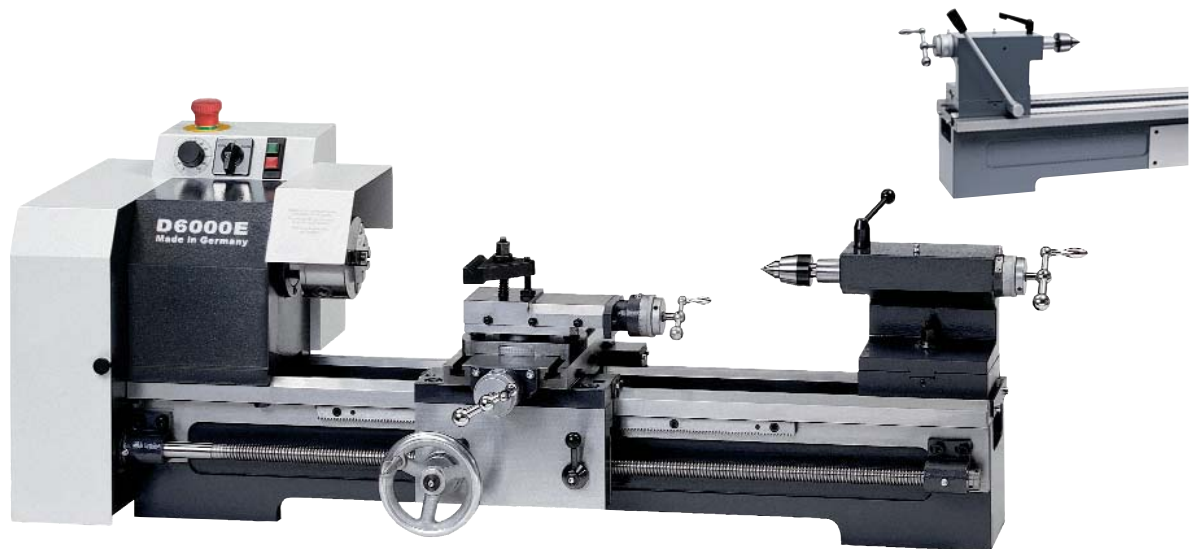

D6000 E

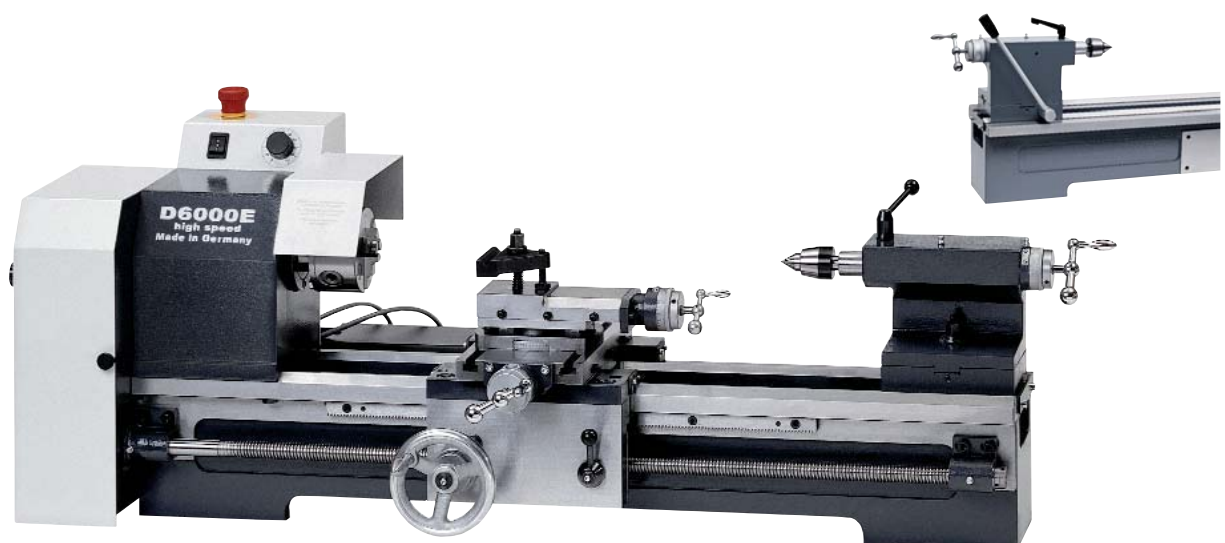

D6000 E high speed

... for all lathes

- 5-year warranty
- we guarantee ultimate precision due to **production in Germany** on state-of-the-art machine tools
- **with hardened prismatic cast iron bed**
- made to toolmaker's accuracy with test report
- work spindle bore Ø 20 mm (optional Ø 30 mm for all lathes D6000 E)
- precision lathe chuck with turning and drilling jaw
- live lathe centre MT2
- clockwise/anticlockwise rotation of work spindle
- tumbler gear for left and right threads
- change gear set for **threading** metric (0.4-4.0 mm) and inch (10-32 TPI) threads
- 2 automatic longitudinal feeds rates/lead screw drive
- constant torque throughout the entire speed range

... especially for lathes D4000 E

- with electronically infinitely variable drive **30 - 2300 r.p.m.** Equipped with a strong work spindle drive with dynamic, speed-controlled main drive motor, which can be adjusted by means of a potentiometer over a wide range of cutting speeds
- with single-phase inverse-speed motor **1.4 kW, 230 V, 50 Hz** as a direct current model with continuous r.p.m. surveillance
- also available in 110V - 60 Hz and inch model

with 3-jaw lathe chuck Ø 100 mm	Order No. 10400
with 3-jaw lathe chuck Ø 125 mm	Order No. 10401
with 4-jaw lathe chuck Ø 125 mm	Order No. 10402

... especially for lathes D6000 E

- with electronically infinitely variable drive **30 - 2300 r.p.m.** Equipped with a strong work spindle drive with dynamic, speed-controlled main drive motor, which can be adjusted by means of a potentiometer over a wide range of cutting speeds
- with single-phase inverse-speed motor **1.4 kW, 230 V, 50 Hz** as a direct current model with continuous r.p.m. surveillance
- **teilstock with quick-release**
- also available in 110V - 60 Hz and inch model

with 3-jaw lathe chuck Ø 100 mm	Order No. 10600
with 3-jaw lathe chuck Ø 125 mm	Order No. 10601
with 3-jaw lathe chuck Ø 160 mm	Order No. 10603
with 4-jaw lathe chuck Ø 125 mm	Order No. 10602

... especially for lathes D6000 E high speed

- robust, speed regulated motor, which can be adjusted by means of a potentiometer over a wide range of cutting speeds. Power **2.0 kW, 230 V, 50 Hz**
- spindle speed **100 - 5000 r.p.m.** (with lathe chuck Ø 125 mm max. 4800 r.p.m.)
- suitable for small diameter tools due to high speed
- **teilstock with quick-release lever**

with 3-jaw lathe chuck Ø 100 mm	Order No. 10605
with 3-jaw lathe chuck Ø 125 mm	Order No. 10606
with 4-jaw lathe chuck Ø 125 mm	Order No. 10607

Basic equipment

... for all D6000 E lathes equipped with Camlock fixture

- 5-year warranty
- we guarantee ultimate precision due to **production in Germany** on state-of-the-art machine tools
- **with hardened prismatic cast iron bed**
- **tailstock with quick-release lever**
- made to toolmaker's accuracy with test report
- work spindle bore \varnothing 20 mm (optional \varnothing 30 mm for all CNC lathes CC-D6000 E)
- **Precision Camlock lathe chuck with turning and drilling jaws**
Camlock spindle holder according to DIN 55029 size 4
for quick changing of lathe chucks and collet chucks by means of the quick-fastener
- live lathe centre MT2
- clockwise/anticlockwise rotation of work spindle
- tumbler gear for left and right threads
- change gear set for **threading** metric (0.4-4.0 mm) and inch (10-32 TPI) threads
- 2 automatic longitudinal feed rate/lead screw drive
- constant torque throughout the entire speed range

... especially for lathes D6000 E

- with electronically infinitely variable drive **30 - 2300 r.p.m.** Equipped with a strong work spindle drive with dynamic, speed-controlled main drive motor, which can be adjusted by means of a potentiometer over a wide range of cutting speeds
- with single-phase inverse-speed motor **1.4 kW, 230 V, 50 Hz** as a direct current model with continuous r.p.m. surveillance

with Camlock 3-jaw lathe chuck \varnothing 125 mm

Order-No. 10630

with Camlock 4-jaw lathe chuck \varnothing 125 mm

Order-No. 10632

... especially for lathes D6000 E high speed

- robust, speed regulated motor, which can be adjusted by means of a potentiometer over a wide range of cutting speeds. Power **2.0 kW, 230 V, 50 Hz**
- spindle speed **100 - 5000 r.p.m.** (with lathe chuck \varnothing 125 mm max. 4800 r.p.m.)
- suitable for small diameter tools due to high speed

with Camlock 3-jaw lathe chuck \varnothing 125 mm

Order No. 10636

with Camlock 4-jaw lathe chuck \varnothing 125 mm

Order No. 10638



Technical Data

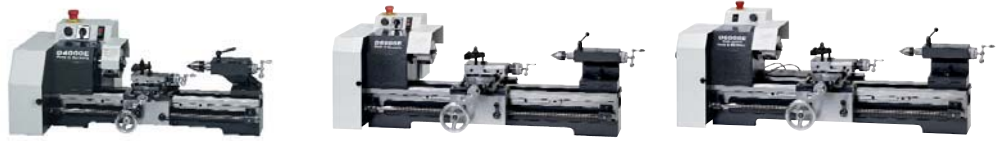

	D4000 E	D6000 E	D6000 E high speed
Centre distance	350 mm	600 mm	600 mm
Centre height	100 mm	135 mm	135 mm
Power 230 V, 50 Hz	1.4 kW	1.4 kW	2.0 kW
Spindle speed infinitely variable	30 - 2300 r.p.m.	30 - 2300 r.p.m.	100 - 5000 r.p.m.
Spindle bore	20 mm	20 mm optional 30 mm	20 mm optional 30 mm
Taper in spindle nose	MT3	MT3	MT3
Ø-of chuck work above cross slide rest	120 mm	170 mm	170 mm
Travel of cross slide	100 mm	140 mm	140 mm
Travel of longitudinal slide	50 mm	60 mm	60 mm
Swivel range of the upper slide rest	360 °	360 °	360 °
max. height of turning tools	16 mm	20 mm	20 mm
Truth of rotation of spindle nose	0.005 mm	0.005 mm	0.005 mm
Cylindrical turning to 100 mm unsupported	0.01 mm	0.01 mm	0.01 mm
Ø of chuck work, measured above the guiding bars	200 mm	270 mm	270 mm
Travel of tailstock sleeve	45 mm	65 mm	65 mm
Tailstock sleeve taper	MT2	MT2	MT2
Tailstock offset range	± 10 mm	± 10 mm	± 10 mm
Automatic feed	0.085 and 0.16 mm	0.085 and 0.16 mm	0.085 and 0.16 mm
Thread pitch metric thread inch thread	0.4-4.0 mm 10-32 TPI	0.4-4.0 mm 10-32 TPI	0.4-4.0 mm 10-32 TPI
Machine dimensions (W x H x D)	860 x 400 x 380 mm	1230 x 500 x 470 mm	1200 x 630 x 479 mm
Weight net without packing	71 kg	150 kg	177 kg

- Technical details are subject to change -

Options

Work spindle bore Ø 30 mm

- no retrofitting
- with ground inner taper MT3
- not available for lathe D4000 E

Order No. 10678

Ball screws

- no retrofitting
- for both axes
- very high pitch and positioning precision
- wear-free
- **incl. lead-or ball screw protective cover**
- not available for lathe D4000 E

Order No. 10645

Lead-or ball screw protective cover

- no retrofitting
- to protect the leading spindle and nut against swarf
- to prevent premature wear and loss of precision
- not available for lathe D4000 E

Order No. 10680

Quick-action collet chuck

- no retrofitting
- quick clamping device for interchangeable collet chucks
- clamping range 1 - 30 mm
- **to be used only up to max. 4000 r.p.m.**
- clamping and unclamping of the work piece done by hand lever
- self-locking
- collets from 1 - 30 mm available - price upon request
- not available for lathe D4000 E

Order No. 10930

Base cabinet

- H 85 x W 106 x D 45 cm
- with 2 lockable doors and 2 shelves
- made of powder-coated sheet steel

Order No. 10267

Levelling elements

- vibration pick up and absorption element
- Ø 80 mm, thread M10
- prevents the machine and cabinet moving
- for precise height adjustment on uneven ground
- 4 levelling elements are required per cabinet/machine

pack. unit: 1 piece

Order No. 10268



**Illustration D6000 E
with ball screws and
lead-or ball screw protective cover**



Coolant unit with splash guard

- for optional retrofitting
- for cooling and lubrication
- complete with feed pump 230 V, 50 Hz
- flexible hose with stop valve and nozzle
- content coolant: 19 liters

Application: i. e. when processing high alloy steel and aluminium, improves the surface finish, increases tool endurance, prevents built-up edges, maintains dimensional accuracy of work pieces



for D4000 E	Order No. 10464
-------------	-----------------

for D6000 E/D6000E high speed	Order No. 10664
-------------------------------	-----------------

Universal drilling and milling unit DF1680 E

- for optional retrofitting
- product description see page 40
- not available for lathes D4000 E

Order No. 10692



Angle plate with milling table

- for optional retrofitting
- complete with milling table and vertical slide rest
- for drilling and milling
- can be traversed in 3 axes
- work bench 130 x 100 mm
- work bench can be rotated infinitely variable 360°

for D4000 E	Order No. 10470
-------------	-----------------

for D6000 E/D6000 E high speed	Order No. 10671
--------------------------------	-----------------



Start set 1

consisting of:

- universal carbide tipped tools set 6-pieces
- precision quick-action drill chuck with taper shaft for drill chuck
- square turret tool-post

for D4000 E	Order No. 10994
-------------	-----------------

for D6000 E/D6000 E high speed	Order No. 10996
--------------------------------	-----------------



Start set 2

consisting of:

- universal carbide tipped tools set 6-pieces
- precision quick-action drill chuck with taper shaft for drill chuck
- quick-change tool holder, basic body
- holder for drill steel
- holder for turning steel

for D4000 E	Order No. 10997
-------------	-----------------

for D6000 E/D6000 E high speed	Order No. 10995
--------------------------------	-----------------



Options

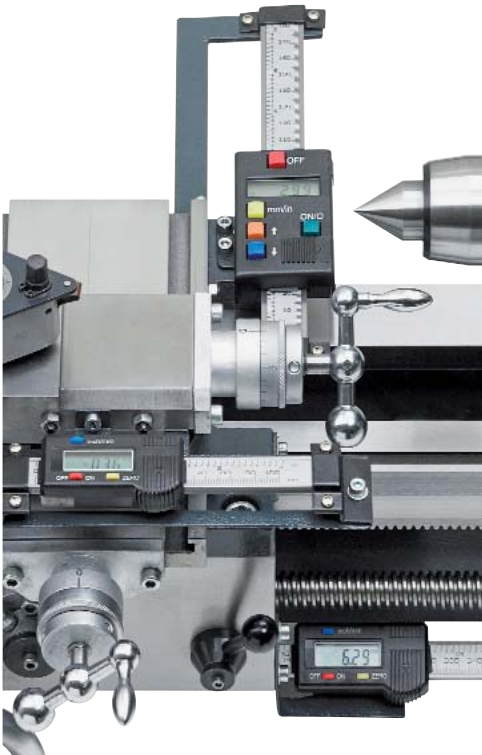

Digital measuring gages

- for optional retrofitting
- digital measuring gages for precise and exact processing of a work piece, without monitoring spindle play
- the digital measuring slide shows values with a reading accuracy of 0.01 mm on the LCD display
- reversible metric/inch
- all digital measuring gages are equipped with an interface for position readout
- Reset function
- can be installed by the customer

Digital measuring gage transverse X-axis

- | | | |
|--|---|---|
| <ul style="list-style-type: none"> ■ for allen D4000 E ■ for allen D6000 E | <p>measuring length 100 mm</p> <p>measuring length 150 mm</p> | <p>Order No. 11370</p> <p>Order No. 11371</p> |
|--|---|---|

Digital measuring gage longitudinal Z-axis

- | | | |
|--|---|---|
| <ul style="list-style-type: none"> ■ for allen D4000 E ■ for allen D6000 E | <p>measuring length 400 mm</p> <p>measuring length 500 mm</p> | <p>Order No. 11364</p> <p>Order No. 11365</p> |
|--|---|---|

Digital measuring gage upper longitudinal support Z-axis

- | | | |
|----------------------------------|--------------------------------|------------------------|
| <p>with vertical LCD display</p> | <p>measuring length 100 mm</p> | <p>Order No. 11360</p> |
|----------------------------------|--------------------------------|------------------------|

Set of fastenings for all 3 axes

- | | |
|--|---|
| <ul style="list-style-type: none"> ■ for allen D4000 E ■ for allen D6000 E | <p>Order No. 10499</p> <p>Order No. 10699</p> |
|--|---|

Factory-installed readout system and glass measuring gages

Order No. 10698

3-axis digital readout system and linear measuring scales

- switchable from lathes to milling machines
- for a precise, fast and reliable production
- smooth installation by exact positioning
- no parallax or reading errors
- absolute accuracy of repeat machining
- glass measuring scales are protected against shock and dirt
- colour display, 7-digit position indicator and +/-display
- resolution 0.005 mm
- ergonomically designed folio keyboard – dust and splash guard
- reversible metric/inch
- reversion of count (up and down) by means of operation sign change
- coordinates value setting or zero setting
- data is preserved in the fixed set point memory in the case of a power cut
- incremental or absolute measurement input
- parameter input
- diameter or radius readout
- display of the axes Z0 and Z1 with adding function, either the addition value or the individual values are displayed
- can be installed by the customer



**Illustration D6000 E
with 3-axis digital readout system**

3-axis digital readout system		Order No. 10280
Linear measuring scales for longitudinal X-axis	measuring length 170 mm	Order No. 10284
Linear measuring scales for longitudinal Z-axis		
■ for D4000 E	measuring length 320 mm	Order No. 10286
■ for D6000 E/D6000 E high speed	measuring length 520 mm	Order No. 10287
Bracket for readout system and protective cover for the glass measuring scales		
■ for D4000 E		Order No. 10489
■ for D6000 E/D6000 E high speed		Order No. 10689
Factory-installed readout system and glass measuring scales		Order No. 10688