

SHERLINE
PRODUCTS
INCORPORATED 1974

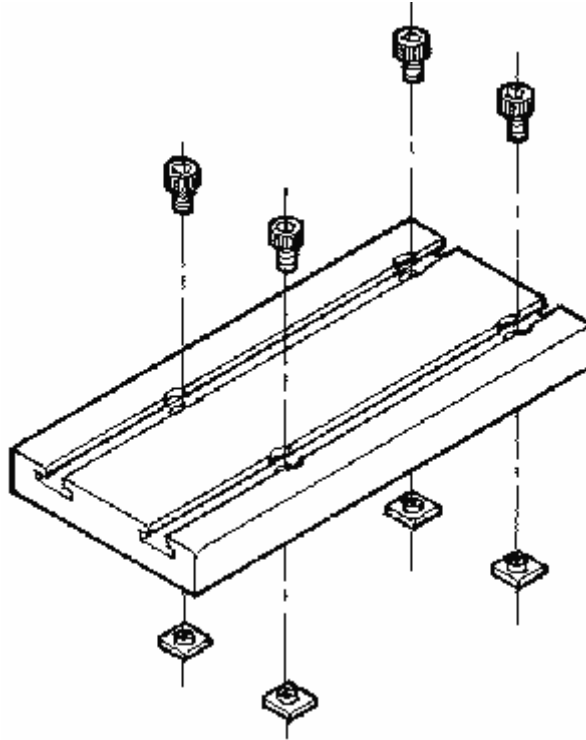

SHERLINE Crossslide Accessory Plate

P/N 3017

Use of the crossslide accessory plate

Though fitted to the lathe, this is actually an accessory designed for milling. The table on the mill is thicker than the table on the lathe because of the greater forces transferred to the table in milling and the requirement for stiff setups. When using the vertical milling column on the lathe, the table can be "beefed up" with the addition of this plate which adds 1/2" (12.7mm) of thickness to the table. It also serves as a tooling plate which protects the surface of your lathe table from damage. It should be removed for lathe turning or the toolpost will be holding the cutting tool 1/2" too high. Also, clearance over the table would be needlessly reduced by the same amount.