

SHERLINE PRODUCTS

INCORPORATED 1974

WW COLLET ADAPTER

P/N 2085 (SHERLINE WW)

P/N 2086 (8MM WW)

The purpose of the WW collet adapter is to allow the use of WW collets in the lathe tailstock. I decided to add this product to the accessory line based on the requests of several watchmakers. They have a need to drill very small holes with the accuracy only a collet can provide. A drill of only a few thousandths of an inch in diameter is easily broken if not perfectly centered. To accomplish this level of accuracy on a Sherline lathe, a little extra time must be spent to "perfectly" align the machine. When you consider the alternative is to spend thousands of dollars for a jeweler's lathe that is far less versatile, I think you will find it is time well spent.

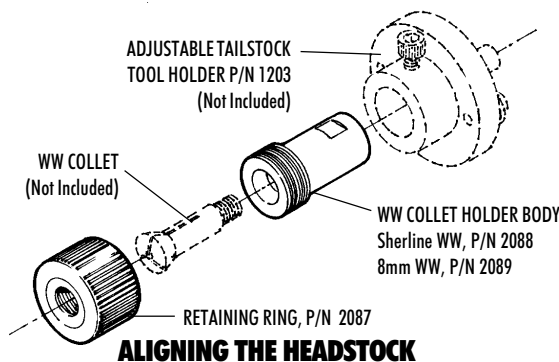

The first step is to align the Headstock with the Bed. Loosen the headstock and push it back evenly against the alignment key (located under the headstock) and retighten. Put a scrap piece of round material about 5/8" (16mm) diameter by 3" (76mm) long in the 3-jaw chuck, turn the outside diameter to round and face the end with a sharp cutter. Measure the taper that has been cut and eliminate it by moving the headstock with light taps from a mallet and taking another test cut until any error is eliminated.

You now must make the choice of whether you want the headstock to remain removable. A simple way to "lock it in" is to use Loctite™ on the keyway. Make sure the alignment key and keyway are free from oil before aligning the headstock. After alignment, turn the lathe on end and place a few drops of thread locking compound into the keyway. The headstock can later be loosened by prying with a screwdriver blade in the slot between the bottom of the headstock and the lathe bed when viewed from the headstock end.

Another method would be to pin the headstock to the bed with 1/8" dowel pins after alignment. To do this, carefully remove the base from the lathe and drill and ream two 1/8" holes about 2.5" (63mm) apart through the bed and into the headstock. You must do this without moving the headstock on the bed. The headstock can be removed this way, although it is a little more difficult than using just the keyway. When it is reinstalled, however, it should align closer than with the standard keyway.

(My personal opinion is that you will give up more than you gain if you lock down the headstock, as most work can be accomplished with standard keyway alignment. However, if the ultimate in accuracy is your goal, the choice is up to you.)

ALIGNING THE ADJUSTABLE TAILSTOCK TOOLHOLDER

The adjustable tailstock tool holder, part number 1203, is designed to allow minute adjustment of the tailstock center. Complete instructions on how to accomplish this adjustment are included with that accessory.

With the headstock in alignment, a dial indicator can be used to "indicate in" the WW collet. (See "Use of a Dial Indicator" section in the *Sherline Instruction Guide*.) Another method would be to turn a short length on the end of the sample stock down to 1/16". Then chuck up a piece of 1/16" material in a 1/16" WW collet held in the adapter. Bring the ends of the two pieces of material right up to each other and, using a magnifying glass, align the ends by eye.

The collet adapter comes in two sizes: Sherline WW and 8mm. The difference between them is .002" diameter on the barrel part of the collet. The Sherline WW is .313" diameter and the 8mm is .315" diameter.

I believe micromachinists and watchmakers will find this accessory to be most useful. By using this simple tool and a little time, you can duplicate the accuracy of a machine costing many times more, yet still retain the great versatility offered by your Sherline Lathe.

—Joe Martin, President and Owner
Sherline Products